

## Application

The Erie™ Modulating PopTop™ Series valve actuator assemblies are designed for closed hydronic heating and cooling systems. The Modulating PopTop is used to control fluid flow in fan coil units, VAV reheat, unit ventilators, AHUs and radiant applications.

The Modulating PopTop Proportional (P) type is compatible with any 0 to 10 Vdc or 4 to 20 mA signal with jumper selectable operating range and action resulting in precise positioning. The floating (T) type is compatible with any 24 Vac three-wire signal when three minute time-out logic resides in the valve actuator or system controller.

The Modulating PopTop valve assemblies allow the actuator to be snapped onto, or off from, the valve body. The actuator can be mounted after the valve body has been installed into the system without the need for linkages or calibration.

Available in standard (non-spring return) and spring return modulating actuators. The two-way spring return modulating actuators are provided in either normally open or normally closed operation. The three-way valves are available in normally closed operation only. Valve body reversal provides normally open flow for three-way valve bodies.

## Features

- Magnetic clutch to maximize the life of the motor and gear train
- Manual operating lever/position indicator facilitates field setup
- Easy to use lever terminal blocks
- Actuator can be installed after the valve body
- Three wire floating and 0 to 10 Vdc or 4 to 20 mA proportional available
- Spring return will return actuator to normal position when the power is lost for more than two minutes.

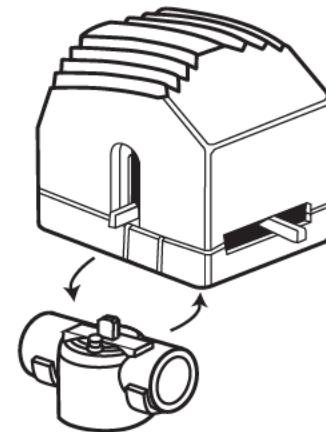

Spring Return

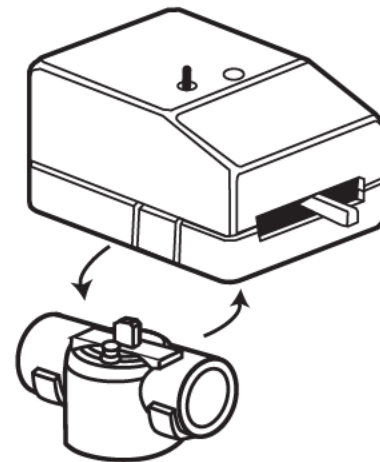

Non-Spring  
Return

## Applicable Literature

- EN-205 Water and Steam System Guidelines, F-26080

## Part Numbering System Modulating Spring and Non-Spring Return Zone Valves

△ 1 V M X X X X X X 3 A 00 X △ 2

**Body Type**  
M = Modulating

**Configuration**  
2 = 2-Way  
3 = 3-Way

**Valve Size**  
2 = 1/2"  
3 = 3/4"  
4 = 1"  
5 = 1-1/4"

**Options**  
**Non-Spring Return Actuators**  
0 = No Options  
T = Three-Wire Signal Time-Out  
  
**Spring Return Actuators**  
T = Time-Out △ 3

**Electrical Leads**  
00 = No leads

**Voltage**  
A = 24 Vac Only

**Temperature Ratings**  
3 = General Temperature

Connection Type	Availability
1 = Sweat	1/2", 3/4", 1", 1-1/4"
2 = Threaded NPT	1/2", 3/4", 1"
3 = Threaded Rp (Metric)	1/2", 3/4", 1"
5 = SAE Flare	1/2"

**Action**  
1 = Spring Return Normally closed  
2 = Spring Return Normally opened  
3 = Non-Spring Return

CV Size			
		Size	Connection Type
1 =	1.0	1/2"	1, 2, 3, 5
		3/4"	1, 2, 3
2 =	2.0	1/2"	1, 2, 3, 5
		3/4"	1, 2, 3
		1"	1
3 =	4.0	1/2"	1, 2, 3, 5
		3/4"	1, 2, 3
7 =	7.5	3/4"	1, 2, 3
		1"	1, 2, 3
	8.0	1"	1, 2, 3
		1-1/4"	1

**Actuator Type**  
T = Three-wire Floating  
P = Proportional, 0-10 Vdc, 0-5 Vdc,  
5-10 Vdc or 4-20 mA, Jumper Selectable

- △ 1 When ordering valve body only: use the first six positions to configure the valve.
- △ 2 When ordering actuator only: use the last seven positions to configure the actuator. Prefex with the letter "A."
- △ 3 This feature is standard for spring return actuators. It must be included in the part number.
- △ 4 Should not be used with thermostats/ controllers unless they have a timeout feature.

Available Actuators				
Part Number	Action	Position	Actuator Type	Option
AT13A00T	Spring Return	N.C.	Three Wire Floating	With Time-Out
AT23A00T	Spring Return	N.O.	Three Wire Floating	With Time-Out
AT33A000	Non-Spring Return		Three Wire Floating	None
AT33A00T	Non-Spring Return		Three Wire Floating	With Time-Out
AP13A000	Spring Return	N.C.	Proportional	None
AP23A000	Spring Return	N.O.	Proportional	None
AP33A000	Non-Spring Return		Proportional	None

△ 4

# SPECIFICATIONS

## Inputs

Floating Actuator			Control Circuit, Max.		Total Actuator, Max.	
					Powerup Inrush <sup>a</sup>	Running
Series	Action	Vac	mA	VA	VA	VA
AT13A00T	Spring Return	24 Vac +25%/-15% 50/60 Hz	24	0.6	10	1.9
AT23A00T			24	0.6		1.9
AT33A000	Non- Spring Return		-	-	1.0	1.0
AT33A00T			-	-	1.2	1.2

a Transformer must be sized for Powerup Inrush

Proportional Actuator			Control Circuit, Max.		Total Actuator, Max.	
					Powerup Inrush <sup>a</sup>	Running
Series	Action	VAC	Range	Rin	VA	VA
AP13A000	Spring Return	24 Vac +25%/-15% 50/60 Hz	0-10 VDC <sup>b</sup> or 0-5 VDC or 5-10 VDC or 4-20 mA	>200K >200K >200K 300	10	1.7
AP23A000						
AP33A000	Non-Spring Return				1.7	

a Transformer must be sized for Powerup Inrush  
b Factory supplied. Actual range is 1-9 Vdc.

## Outputs

### Timing:

Series	Mode	Action	Nominal Stroke Time		Total Run Time	
			60 Hz	50 Hz	60 Hz	50 Hz
AT13A00T	Floating	Spring Return	2 min. 30 sec.	3 min.	3 min.	3 min. 36 sec.
AT23A00T					no delay	
AT33A000		Non-Spring Return			3 min. ± 30 sec.	na
AT33A00T						
AP13A000	Modulating	Spring Return	2 min. 30 sec.	3 min.	2 min. 45 sec.	3 min. 18 sec.
AP23A000						
AP33A000		Non-Spring Return				

### Mechanical:

**Action, T series:** Direct acting.

**P series:** Direct acting (valve opens port B with increase in signal.) Field selectable reverse acting.

**Manual Override,** Allows manual positioning.

**Operating Pressure Limits,** 400 psi (2758 kPa) static pressure.

#### Material,

**Actuator:** High temperature plastic.

**Valve:** Body: Forged brass; stem: nickel-plated/chrome-plated brass; seat: brass, plug/paddle: high temperature thermoplastic/rubber.

**Flow Characteristic,** 1.0 to 4.0 Cv: equal percentage. 7.0/8.0 Cv: linear.

## Environment

### Ambient Temperature Limits:

**Shipping & Storage,** -40 to 158°F (-40 to 70°C)

**Operating,** 35 to 125°F (2 to 52°C).

**Fluid,** 32 to 200× F (0× to 93× C) (not steam rated).

**Humidity:** 5 to 95% RH, non-condensing.

**Seat Leakage:** ANSI class IV (0.01%)

**Shipping Weight:** 1.9 lbs (860 g), actuator and valve body.

**Location:** NEMA Type 1.

## Agency Listings (Actuator Only):

**UL873:** Underwriters Laboratories (File #E9429 Category Temperature Indicating and Regulating Equipment) Class 2.

**CUL:** UL Listed for use in Canada by Underwriters Laboratory. Canadian Standards C22.2 No. 24.

**European Community:** CE Approved.

**Australia:** This product meets the requirements to bear the C-Tick Mark according to the terms specified by the Communications Authority under the Radio Communications Act of 1992.

**Table-1 Flow Coefficients & Maximum Close-Off Differential Pressure.**

Valve Size in.	Connection Type	Flow Coefficient Cv (kv)	Maximum Close-Off DP, PSI (kPa)		
			Non-Spring Operating Mode (Driven Close)	Spring Return Operating Mode (Driven Closed)	Spring Return Power Failure Mode* (Spring Close) PSID
1/2	NPT, SW, SAE, Rp	1.0 (0.9)	50 (344)	50 (344)	50 (344)
1/2	NPT, SW, SAE, Rp	2.0 (1.8)	50 (344)	50 (344)	20 (138)
3/4	NPT, SW, Rp				
1/2	NPT, SW, SAE, Rp	4.0 (3.5)	35 (241)	35 (241)	20 (138)
3/4	NPT, SW, SAE, Rp				
1	SW				
3/4	NPT, SW, Rp	7.5 (6.5)	35 (241)	35 (241)	15 (103)
1	SW, p	R 8.0 (6.9)	35 (241)	35 (241)	15 (103)
1-1/4	SW				

\*If valve is driven closed before a power failure, the "operating mode" close-off pressures apply.

#### Valve Body Legend

NPT — Threaded

SW — Sweat

SAE — Society Automotive Engineers.

Rp—"Metric" Threaded

# TYPICAL APPLICATION (wiring diagram)

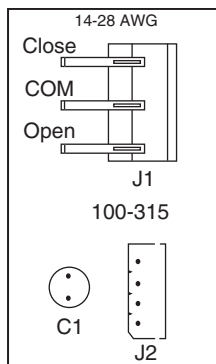

Figure-1 Typical Wiring of Three-Wire Floating Non-Spring Return Valves.

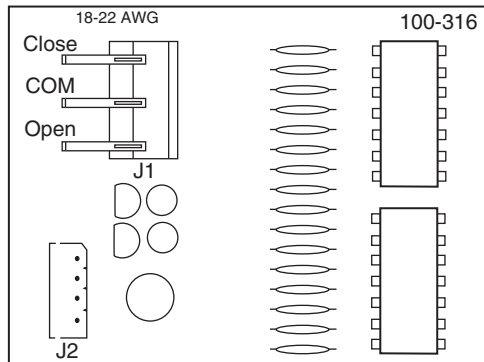
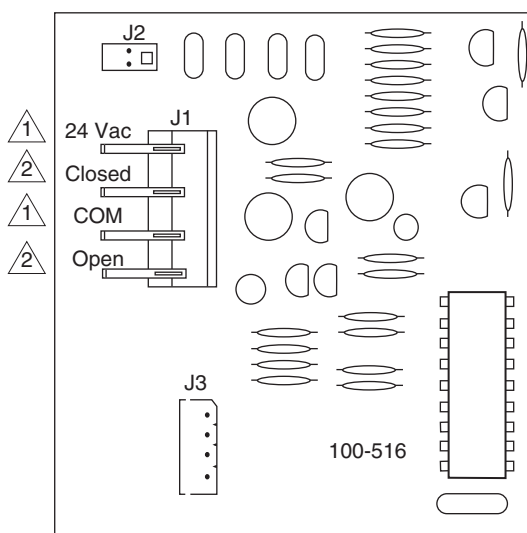

Figure-2 Typical Wiring of Three-Wire Floating Non-Spring Return Valves with Time-Out.



- 1 The 24 Vac/COM supply must be maintained continuously for valve operation. The valve returns to its normal position whenever this supply is interrupted.
- 2 The CLOSE and OPEN control signals share the COM terminal with the 24 Vac supply.

Figure-3 Typical Wiring of Three-Wire Floating Spring Return Valves with Time-Out.

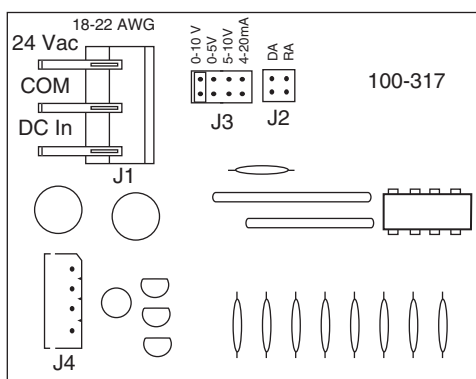

Figure-4 Typical Wiring of Three-Wire Proportional Non-Spring Return Valves.

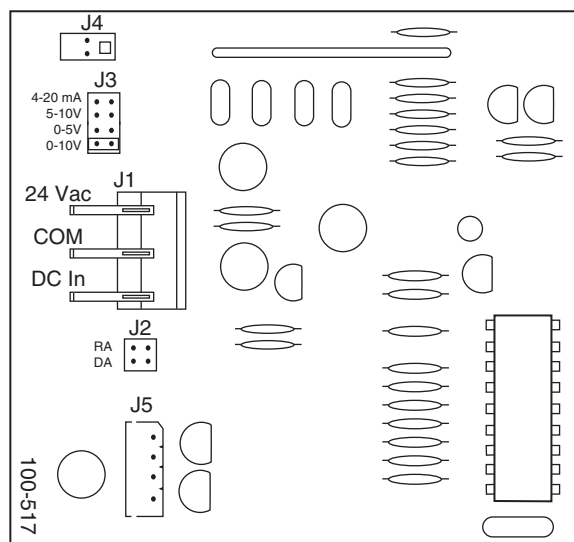

Figure-5 Typical Wiring of Three-Wire Proportional Spring Return Valves.

# INSTALLATION

## Inspection

Inspect the package for damage. If damaged, notify the appropriate carrier immediately. If undamaged, open the package and inspect the device for obvious damage. Return damaged products.

## Requirements

- Tools (not provided):
  - Wrench 1 to 1-5/8" (if threaded valve)
  - Pipe wrench according to pipe size (if threaded valve)
  - Soldering equipment (if sweat fit)
  - #1 Phillips head screw driver
  - Volt-ohm multimeter
- Training: Installer must be a qualified, experienced technician
- Other accessories as appropriate

## Precautions

### General

#### WARNING:

- Electrical shock hazard! Disconnect power before installation to prevent electrical shock or equipment damage.
- Make all connections in accordance with the electrical wiring diagram and in accordance with national and local electrical codes. *Use copper conductors only.*

#### CAUTION:

- Avoid locations where excessive moisture, corrosive fumes, explosive vapors, or vibration are present.
- Avoid electrical noise interference. Do not install near large conductors, electrical machinery, or welding equipment.

### Federal Communications Commission (FCC)

#### NOTE

---

This equipment has been tested and found to comply with the limits for a Class B digital device, pursuant to Part 15 of the FCC Rules. These limits are designed to provide reasonable protection against harmful interference in residential installations. This equipment generates, uses, and can radiate radio frequency energy and may cause harmful interference if not installed and used in accordance with the instructions. Even when instructions are followed, there is no guarantee that interference will not occur in a particular installation. If this equipment causes harmful interference to radio and television reception—which can be determined by turning the equipment off and on—the user is encouraged to try to correct the interference by one or more of the following measures:

- Reorient or relocate the receiving antenna.
  - Increase the separation between the equipment and receiver.
  - Connect the equipment to an outlet on a circuit different from that to which the receiver is connected.
  - Consult the dealer or an experienced radio/television technician for help.
- 

### Canadian Department of Communications (DOC)

#### NOTE

---

This class B digital apparatus meets all requirements of the Canadian Interference-Causing Equipment Regulations.

---

### European Standard EN 55022

#### WARNING:

**This is a class B (European Classification) product. In a domestic environment this product may cause radio interference in which case the user may be required to take adequate measures.**

## Mounting

The Modulating PopTop Series valves can be mounted in horizontal or vertical piping. When installed in horizontal piping, the actuator must be above the valve body. Refer to Figure-6.

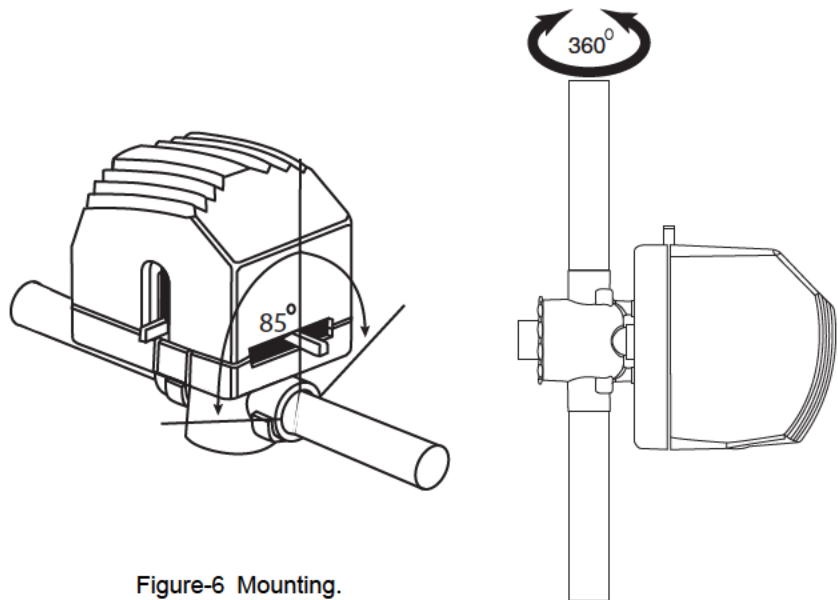

Figure-6 Mounting.

## Piping

Refer to the piping diagrams in Figure-7 for two-way valves. For three-way valves refer to Figure-8.

- The 3-way is only configured as normally closed. For normally open configuration to the coil turn valve around. For proportional valves, set the control action (direct or reverse accordingly).

### WARNING:

- The valve should be used in a closed loop system.
- All valves must be piped so that the plug closes against the direction of flow. For two-way valves, flow is from port B to port A. For normally closed three-way valves, B is the service port and A is the bypass port. For normally open three-way valves, A is the service port and B is the bypass port.
- Three-way VM valves must be piped in a mixing configuration, not diverting.

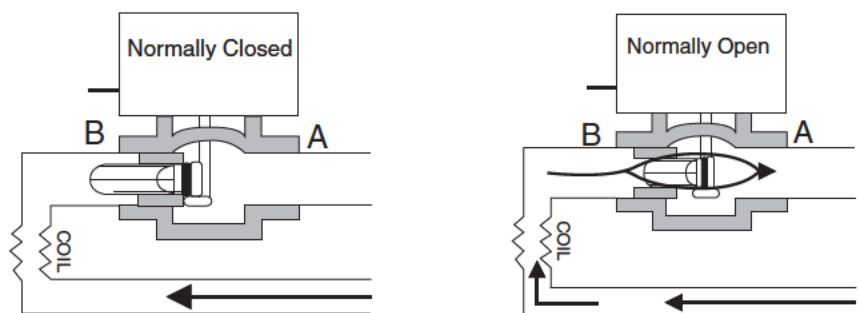

Figure-7 Two-Way Spring Return Valves.

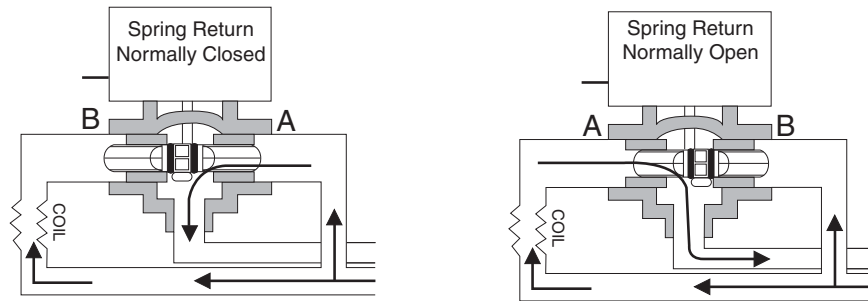

Figure-8 Three-Way Spring Return Valves.

### Sweat End Valves

1. Slowly position the actuator's manual operating lever (on the front of the actuator) to the middle position, to manually open the valve so that the plug is not in contact with the valve body.

#### CAUTION:

- The plug inside the valve is made of a plastic material. It may be damaged by heat conducted through the valve body if it remains seated against its port during soldering. Be sure to manually open the valve before soldering to prevent damage.
  - If the manual operating lever does not move freely for manual positioning, the solenoid may have latched during shipping. Do not force the lever. Instead, first unlatch the solenoid by placing the red manual solenoid latch lever (on the side of the actuator) in the "Up" position, then placing the manual operating lever in the middle position.
2. With the valve in the mid-position, latch the solenoid by placing the manual solenoid latch lever in the "Up" position. Then, detach the actuator by depressing the release button and pulling it away from the valve body (Figure-9).

#### CAUTION:

- Be sure to remove the actuator from the valve body before soldering, to avoid damage to the actuator and to ease the soldering process.
- Use only lead or tin based solder with a melting point below 600×F (315×C).

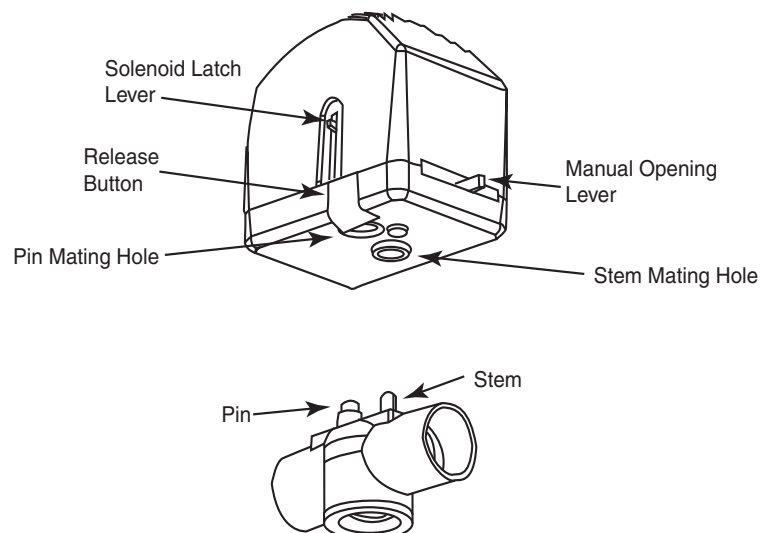

Figure-9 Three-Way Spring Return Valves.

3. Thoroughly clean the ends of the water supply tubing for a minimum distance of 1 inch (25 mm) from the end, so that a good joint can be made in the shortest time and without an excessively large flame.

4. Solder the valve body in place, directing the flame tip away from the valve and taking care not to overheat the joint area. When finished, cool the valve quickly with a wet cloth.

---

**NOTE**

---

The valve body may be submerged in water, or pressurized, for leak testing before reattaching the actuator.

---

5. Reinstall the actuator according to "Reattaching the Actuator to the Valve Body."

**NPT and Rp Threaded Valves**

---

**NOTE**

---

When installing threaded valves, the actuator should be detached from the valve body to ease installation. To do so, first slowly move the actuator's manual operating lever (on the front of the actuator) to the middle position. Then latch the solenoid by placing the red manual solenoid latch lever on the side of the actuator to the "Up" position. Finally detach the actuator by depressing the release button and pulling the actuator away from the valve body (Figure-9).

---

1. Apply teflon tape to all but the last two threads on the end of a properly threaded, reamed, and cleaned pipe. Make sure that pipe chips, scale, etc. do not get into the pipe since this material may lodge in the valve seat and prevent proper closing and opening of the valve.
2. Start the joint by hand-screwing the pipe to the valve. If the thread engages normally, turn the pipe by hand as far as it will go.
3. Use a wrench to fully tighten the valve to the pipe using the flats located on the valve body ports. Take care not to over-tighten or strip the threads.
4. Reinstall the actuator according to "Reattaching the Actuator to the Valve Body."

**Reattaching the Actuator to the Valve Body**

1. Before reinstalling the actuator, be sure that its manual operating lever is in the mid-position, and that the solenoid is latched. The solenoid is latched when the manual solenoid latch lever is in its "Up" position (Figure-9).
2. Depress the release button.
3. Align the valve body with the actuator to ensure the stem is inserted into the large mating hole on the bottom side of the actuator (Figure-9).
4. Engage the actuator on the body and release the button.

## Wiring

---

**NOTE**

---

- Multiple actuators may be connected to a single controller, up to the current rating of the controller and transformer. Do not exceed the maximum current draw of the controller.
  - Use of a properly sized, inherently limited, Class 2 transformer is recommended.
  - Use only 18 to 24 AWG copper wire for all connections.
  - The return spring feature is primarily a safety feature. It is recommended that the spring return feature is not used for routine, normal operation.
- 

**Three-wire Floating**

---

**NOTE**

---

- The three-wire floating spring return valve includes a time-out feature that automatically turns off the control signal to the valve after a pre-determined period of continuous operation. This time period is three minutes at 60 Hz and 3.6 minutes at 50 Hz.
  - Spring return valves feature a two second time delay upon power loss, to prevent the loss of valve position during brief outages. There is a three second delay at power-up.
- 

1. Remove the cover from the actuator, then connect the power and control wiring to the terminal block (Figure-1 and Figure-3).
2. Reinstall the cover onto the actuator.

## Proportional

### NOTE

If multiple proportional valves are used on a single 4 to 20 mA loop, each valve must have its own isolation transformer.

1. Remove the cover from the actuator, then connect the power and control wiring to the terminal block (Figure-4 and Figure-5).

### NOTE

All units are shipped with the actuator in the direct-acting, 0 to 10 Vdc mode, which means that the valve opens the B port upon receiving an increasing Vdc control signal. To change the action to reverse-action (valve closes with an increase in control signal), simply remove the action jumper J2 and relocate it to the reverse-acting pins. See Figure-4 and Figure-5.

2. Reinstall the cover onto the actuator.

## INITIAL SETUP Application Notes

These valves are designed for application to closed hydronic heating and cooling systems. Use in systems which have substantial make-up water (open systems) is not recommended. High levels of dissolved oxygen, chlorine, and debris that may be found in open systems can attack the valve materials and result in premature failure.

### 3-Wire Floating "T" Type

The controller or thermostat used to operate the "T" type must be configured to turn off the control signal after being on continuously for three minutes.

### 3-Wire Floating Time Out "T" Option

If the control system used does not have the ability to limit the running time, then the time out option must be utilized, which automatically cuts off the control signal to the valve after three minutes of continuous operation. This is standard on the spring return, and is an option on the non-spring return.

### Proportional "P" Type

Multiple "P" valves may be connected to a single controller, up to the current rating of the controller and transformer. For 4-20 mA control, a separate isolation transformer must be used with each valve. The actuator is also provided with a jumper to allow the action to be reversed. All units are shipped with the actuator in the DA (direct acting) mode, which means that the valve opens the B port upon receiving an increasing control signal. To change the action to reverse action (valve closes upon receiving an increasing control signal), simply remove the action jumper and relocate it to the RA (reverse acting) pins.

## CHECKOUT

1. Make sure the valve operates freely before installing the valve.
2. If the stem does not operate freely it may indicate that the stem was damaged and may require that the valve be repaired or replaced.
3. After the piping is under pressure check the valve body and the connections for leaks.
4. After the valve and actuators are installed power the actuator and check the operation.
  - a. For two-way model:

Power the valve to the close position (per label), and the "B" port should be closed.
  - b. For three-way model:

Power the valve to the open position (per label), and the "A" port should be closed.
  - c. For Spring Return model:

Removing power should return the actuator to its normal position.

## THEORY OF OPERATION

The PopTop Series floating or proportional modulation valves are modulating valve actuator assemblies. The modulating valves are designed to control the flow in the circuit by making incremental adjustments to the flow path with-in the valve.

The Spring Return PopTop Series modulating valves, when powered, the actuator moves to the desired position, at the same time tensing the spring return system. When power is removed for more than two minutes the spring returns the actuator to the normal position.

## MAINTENANCE

The Modulating PopTop Series valves require no maintenance. Replace defective modules Regular maintenance of the total system is recommended to assure sustained, optimum performance.

## FIELD REPAIR

Replace any damaged or failed components with complete bodies or actuator replacements.

## DIMENSIONAL DATA

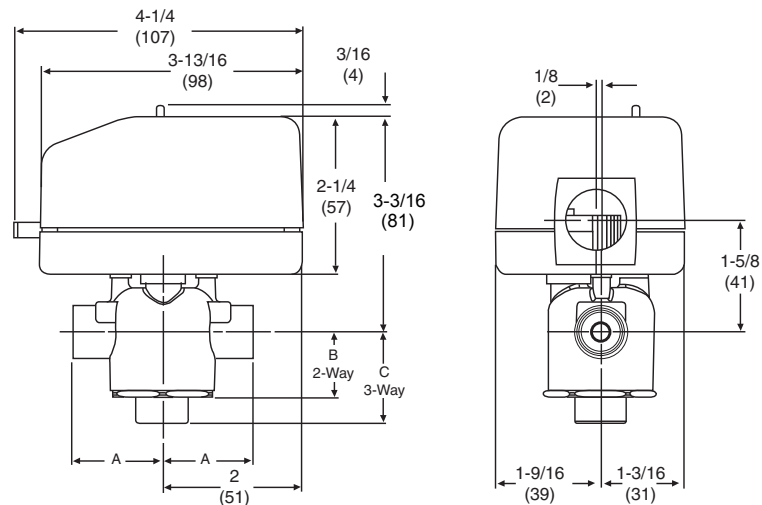

Figure-10 Modulating Non-Spring Return Valve.

Table-2 Dimensions - inches (mm).

Valve Body Size	A	B	C
1/2" Sweat	1-5/16 (33)	15/16 (23)	1-5/16 (33)
3/4" Sweat	1-3/8 (35)	15/16 (23)	1-11/16 (43)
1" Sweat	1-11/16 (43)	15/16 (23)	1-11/16 (43)
1-1/4" Sweat	1-7/8 (47)	1 (25)	1-13/16 (46)
1/2" NPT, Rp	1-3/8 (35)	15/16 (23)	1-5/16 (33)
3/4" NPT, Rp	1-11/16 (43)	15/16 (23)	1-7/16 (37)
1" NPT, Rp	1-7/8 (47)	1 (25)	1-11/16 (43)
1/2" SAE Flare	See Figure-12		

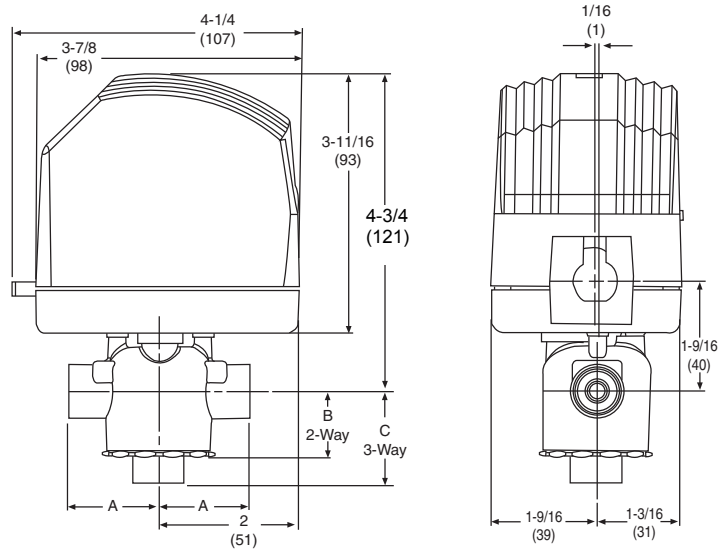

Figure-11 Modulating Spring Return Valve.

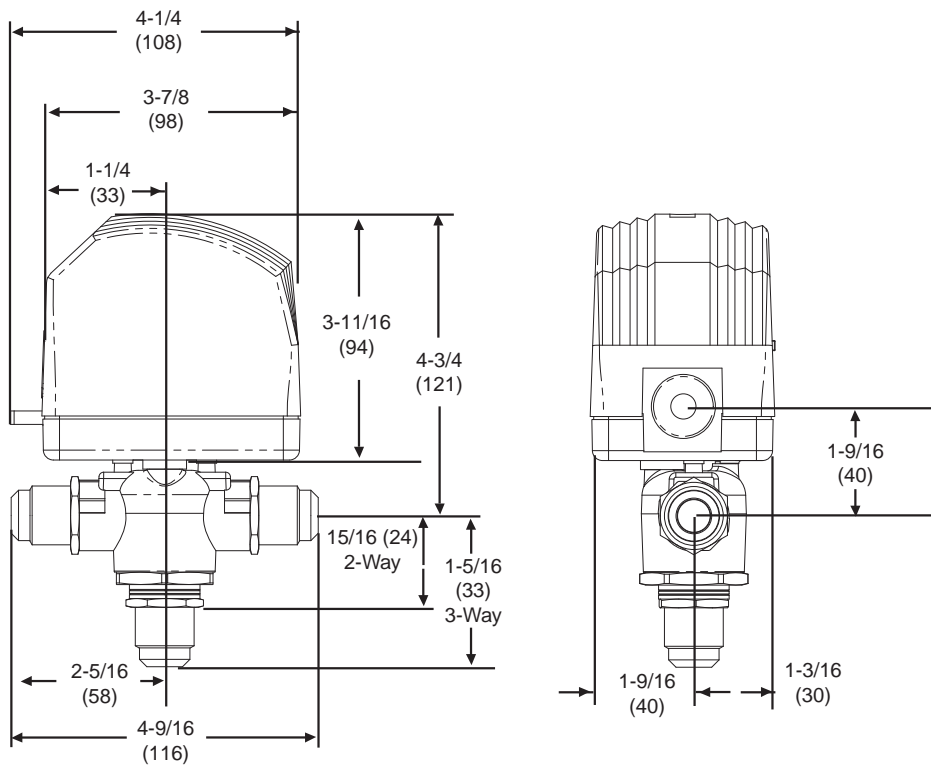

Figure-12 1/2" SAE.